

KINTA®

DR034

MULTI-ANGLE FID BENCH

OWNER'S MANUAL

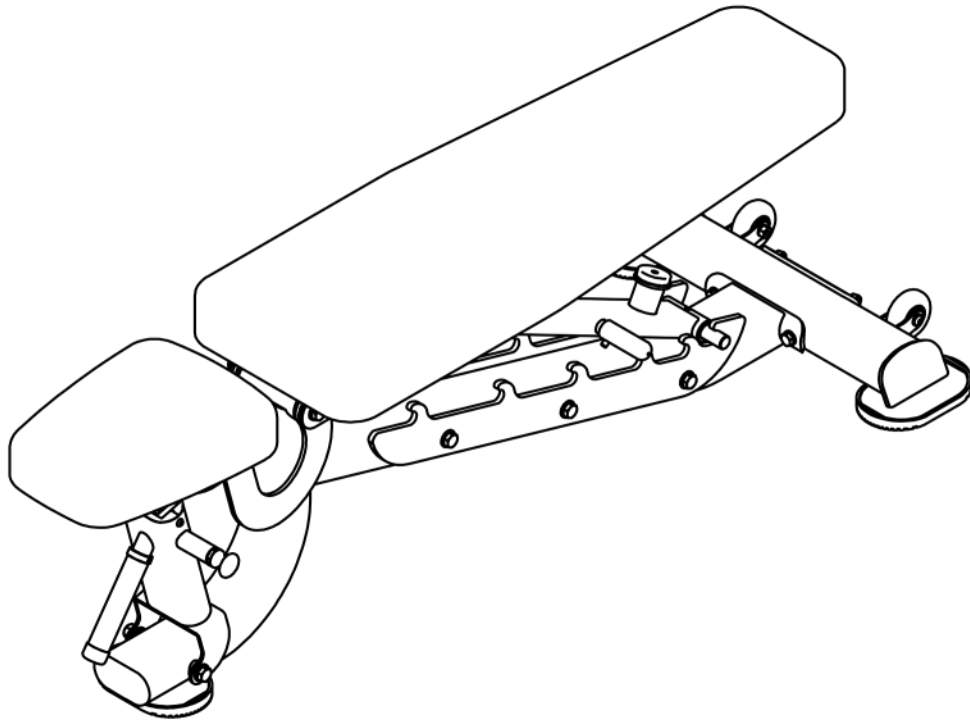

! CAUTION

Read all precautions
and instructions in this manual
before using this equipment

Important Safety Instructions

Before beginning any fitness program, you should obtain a complete physical examination from your physician. When using exercise equipment, basic precautions should always be taken, including the following:

1. Read all instructions before using the equipment.
These instructions are written to ensure your safety and to protect the unit.
2. Use the equipment only for its intended purpose as described in this guide.
Do not use accessory attachments that are not recommended by the manufacturer: such attachments might cause injuries.
3. The product should only be used on a level surface and is with 0.5 meters space around the product.
Do not use the equipment outdoors.
4. Do not allow children on or near the equipment. And children are not allowed to use this equipment.
Teenagers should use this equipment with adult supervision.
5. Do not overexert yourself or work to exhaustion.
Do not attempt to lift more weight than you can control safely.
If you feel any pain or abnormal symptoms, stop your workout immediately and consult your physician.
6. This equipment is not used as medical apparatus and instruments.
7. Never operate the unit when it has been dropped or damaged.
Never drop or insert anything into any opening in the equipment.
Always check the unit and its cables before each use. Make sure that all fasteners and cables are secure and in good working condition.
Frayed or worn cables can be dangerous and may cause injury. Periodically check these cables for any indication of wear.
Keep hands, limbs, loose clothing and long hair well out of the way of moving parts.
8. Be careful when getting on or off the equipment.
9. Wear proper exercise clothing and shoes for your workout, no loose clothing.

Exploded View and Parts List

overall

Item No.	Description	QTY
1	Main Frame ASSY	1
2		
	Bottom Bracket ASSY	1
3	Seat Cushion	1
4	Back Cushion ASSY	1
5.1	Hex Bolt M10*130	2
5.2	Hex Bolt M10*30	6
5.3	Nylon Nut M10	2
5.4	Washer $\varphi 11^* \varphi 20^* 2$	10

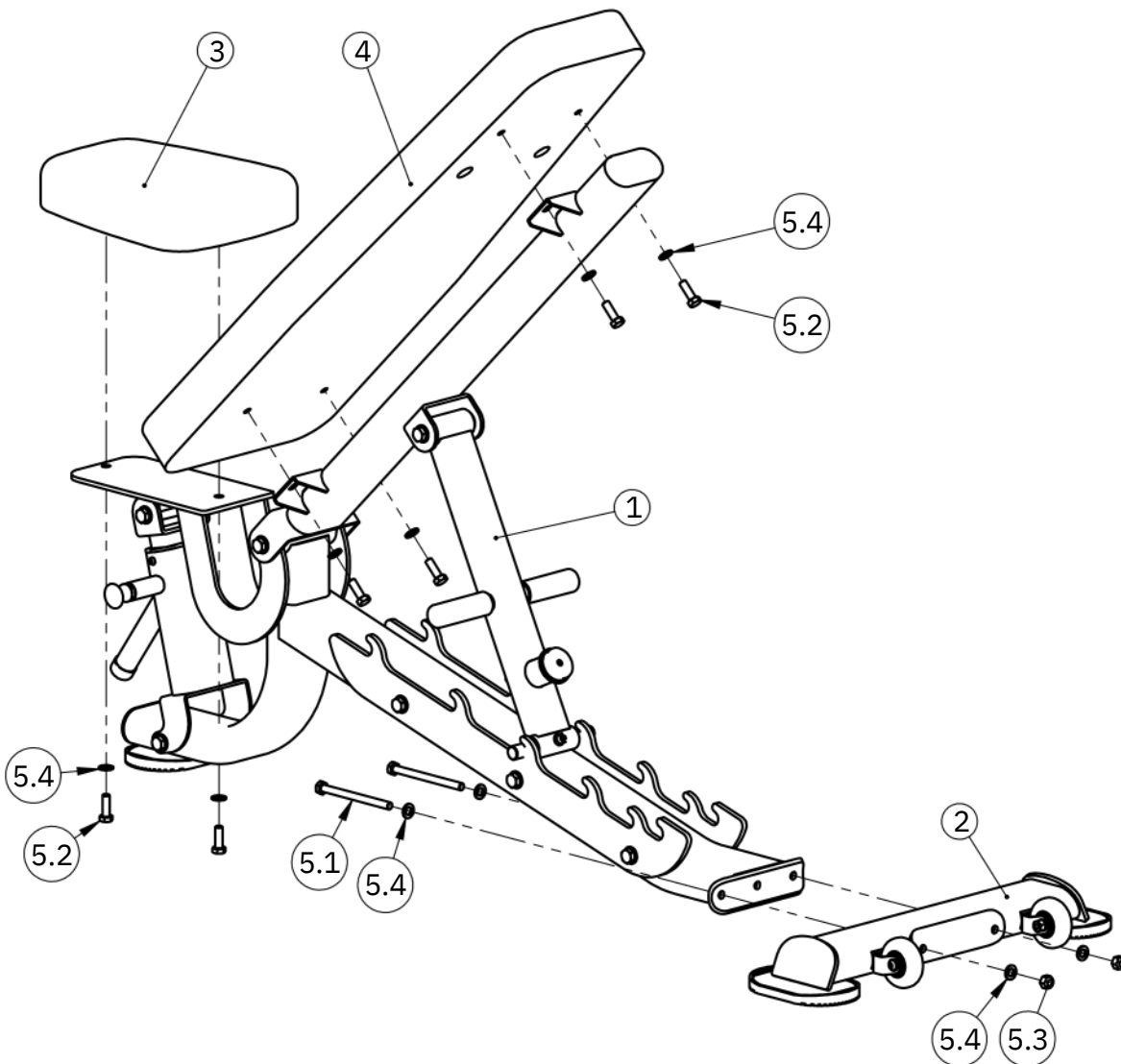

Exploded View and Parts List

Main Frame ASSY

Item No.	Description	QTY	Item No.	Description	QTY
1	Frame	1	20	Rubber Foot	1
2	Adjusting Rack	1	21	Bumper	1
3	Back Cushion Bracket	1	22	Grip	1
4	Seat Cushion Bracket	1	23	Grip	2
5	Adjusting Tube	1	24	Hex Bolt M12*160	1
6	Back Adjusting Bracket	1	25	Hex Bolt M12*140	1
7	Rack Out Plate	2	26	Hex Bolt M12*135	3
8	Shaft	1	27	Hex Bolt M12*110	2
9	Pin	1	28	Socket Head Cap Screw M8*20	1
10	Limiting Rod	1	29	Socket Head Cap Screw M8*30	1
11	Rotating Sleeve	1	30	Button Head Cap Screw M8*45	2
12	Aluminum Caps ϕ 25	1	31	Flat Head Cap Screw M6*15	1
13	ϕ 25 Aluminum Ring	1	32	Socket Set Screw M5*3	2
14	Bushing	2	33	Nylon Nut M12	7
15	Bushing	2	34	Hex Nut M6	2
16	Bushing	2	35	Washer ϕ 13* ϕ 24*1.5	14
17	Bushing	4	36	Washer ϕ 9* ϕ 16*1.6	1
18	Plastic Tube Guide	2	37	Spring Washer ϕ 8	1
19	Plug PT50*100	2	38	Plug ϕ 19	2

Main Frame ASSY

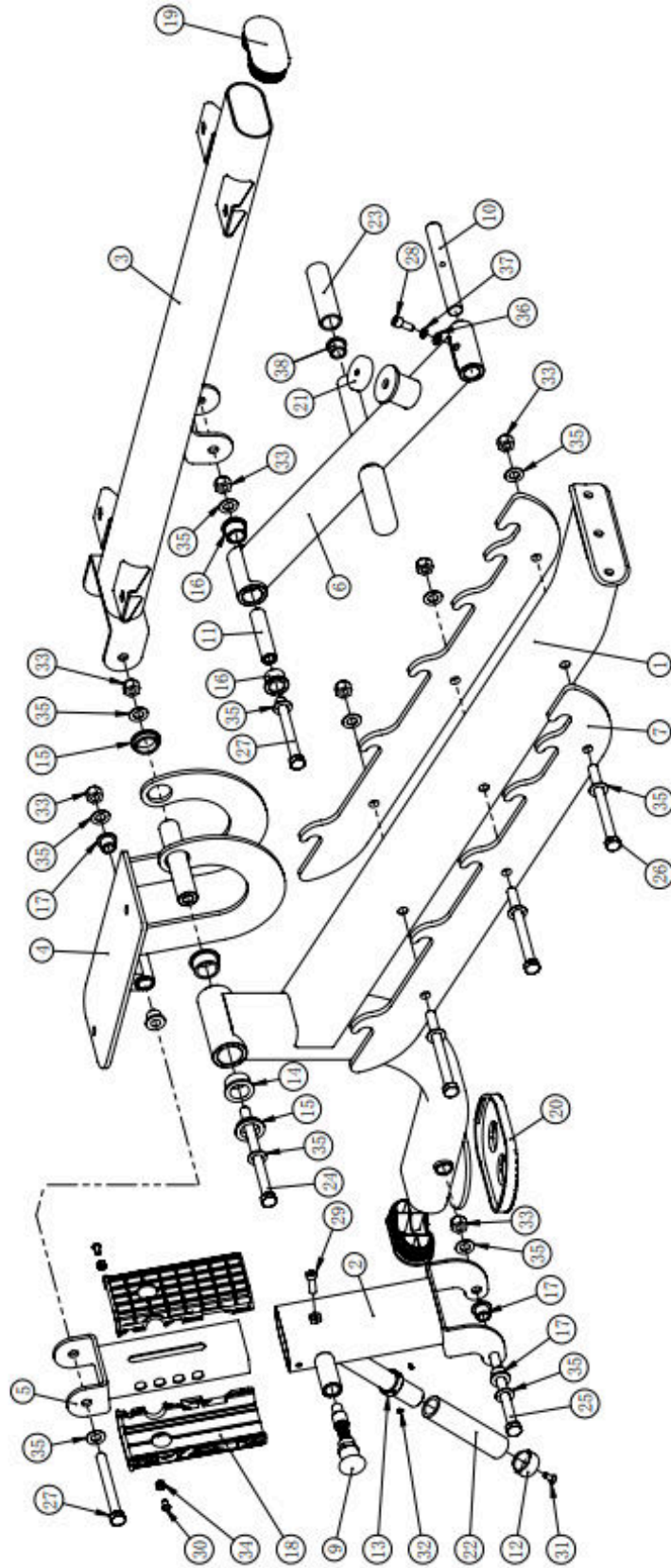

Exploded View and Parts List

Bottom Bracket ASSY

Item No.	Description	QTY
1	Bottom Bracket	1
2	Wheel	2
3	Rubber Foot	2
4	Button Head Cap Screw M8*45	2
5	Nylon Nut M8	2
6	Washer $\varphi 9 * \varphi 16 * 1.6$	4

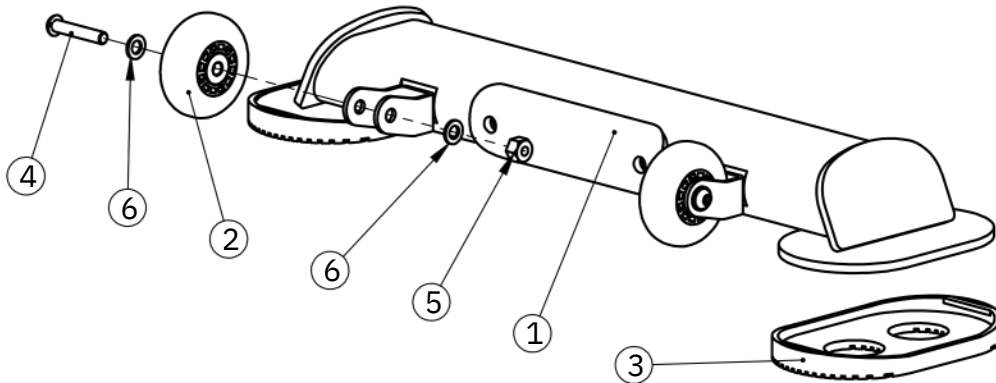

Exploded View and Parts List

Back Cushion ASSY

Item No.	Description	QTY
1	Back Cushion	1
2	Plug	2

